

E-compact instant water heater CEX9 Plus



Application areas

Single point supply:

- > Washbasin
- > Double washbasin
- > Shower

Multiple point supply:

- > Shower and washbasin (in countries with a sufficiently high inlet temperature)



E-compact instant water heater

CEX9 Plus

Product information



Energy efficiency class **A** (Scale: A+ to F) **CEX9 Plus** (Multiple Power System: 6.6 or 8.8 kW adjustable)

Part number:	2400-26470	
Type:	closed-outlet	
Maximum operating pressure [MPa (bar)]:	1 (10) *)	
Water connections (thread connections):	G ½"	
User set temperature [°C]:	20 to 55	
Hot water output at $\Delta t = 33\text{ K}^{1) 2)}$ [l/min]:	2.9	3.8
Switch-on flow rate / max. flow rate ³⁾ [l/min]:	2 / 5	
Nominal power rating ⁴⁾ [kW]:	6.6	8.8
Nominal voltage [1~ / N / PE 220 – 240 V AC]:	Fixed connection	
Nominal current ²⁾ [A]:	29	38
Required cable diameter ²⁾ [mm ²]:	4 – 6	6
Bare wire heating system IES®:	✓	
Ready for Smart Control:	✓ (optional)	
Ready for FX wireless remote control:	✓ (optional)	
Solar-compatible, suitable for reheating (inlet temperature $\leq 60\text{ °C}$):	✓	
VDE approved / Protection class:	✓ / IP 25	
Specific water resistance at 15 °C [Ωcm] \geq :	1100	
Nominal volume [litres]:	0.3	
Weight filled with water [kg]:	approx. 2.7	
Dimensions (height × width × depth) [cm]:	29.4 × 17.7 × 10.4	

*) Also approved for pressureless operation 1) Temperature increase e.g. from 12 °C to 45 °C 2) Depending on the selected power rating 3) Limited flow amount for optimal temperature increase 4) Related to nominal voltage 230 V

Description

- > Electronically controlled instantaneous water heater in compact format as oversink unit with optimal hand shower CXH
- > The heating output is electronically controlled providing an ideal hot water temperature. No need to add cold water at the tap.
- > Sensor-key operation with LED indicator for precise temperature setting between 20 °C and 55 °C
- > Two programming keys for individual pre-set temperatures, activatable temperature limit and operating displays
- > Easy installation facilitated by small dimensions and external ½ inch water connectors
- > Precise temperatures due to TWIN TEMPERATURE control TTC® up to the capacity of the appliance
- > The efficient bare wire heating system IES® reduces lime scale deposits and provides an extended service life
- > With the Multiple Power System MPS®, the maximum power rating is set at the time of installation: 6.6 or 8.8 kW
- > Can also be controlled via tablet or smartphone (iOS 9 or higher / Android-OS 4.4 or higher, FXE3 adapter and the »Smart Control« app required)
- > Solar-compatible (inlet temperature $\leq 60\text{ °C}$)

Profitability comparison (Source: www.clage.com)

Saves up to 40 % energy compared to conventional storage heaters.

The E-compact instant water heater features an economical operation. The water is heated directly as it flows through the unit. Hot water is not stored in a tank, which saves standby energy that would be otherwise required.

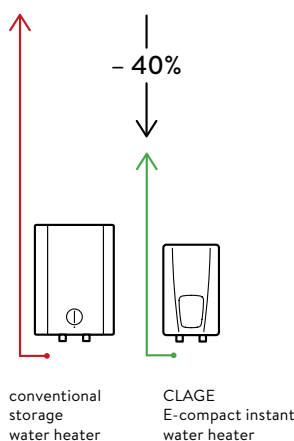

E-compact instant water heater

CEX9 Plus

Installation



Example of installation with **two points of use (closed-outlet)**.

Assembly and operating instructions must be observed upon installation.

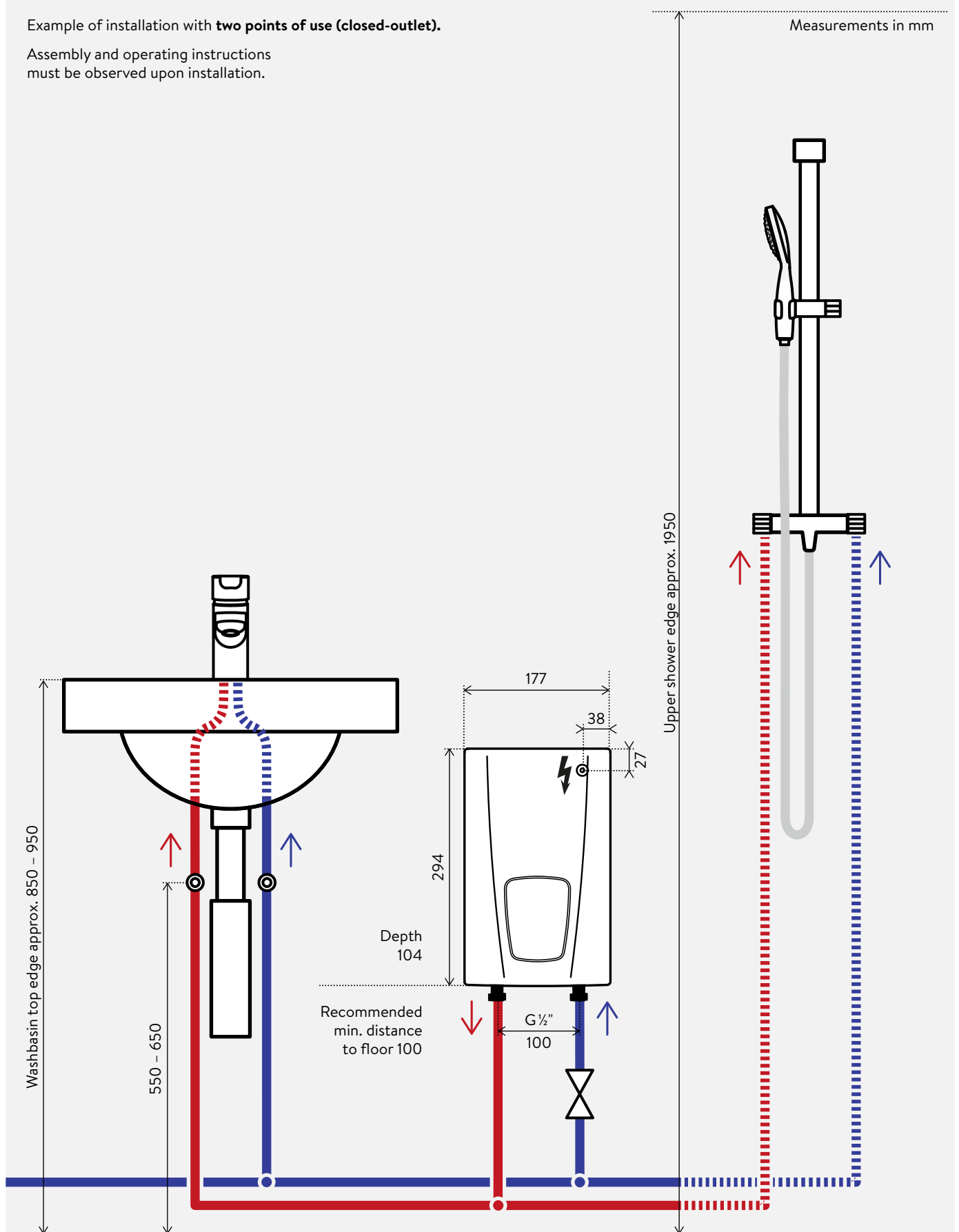



Adjustable hand shower CXH (included)

Hand shower for instant water heater, three modes adjustable, anti-scale insert, chrome.

Dimensions: 24.2 cm length, shower head Ø 9.8 cm

CXH: Part no. 0300-0086



Accessories set (included)

Two seals, two aerator and a G ½-inch valve as a water flow regulation and shut-off option.

Part no. 9400-94515

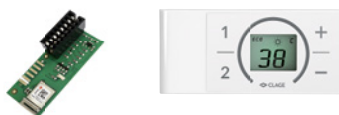

FXS 3 (C) remote control set (optional)

FX3 remote control including Bluetooth® remote control adapter FXE 3 (C) for integration into the instantaneous water heater as a set. In addition to the operation at the device, the remote control allows the comfortable temperature adjustment of the instantaneous water heater over a distance of approx. 10 metres in the building. Secure Bluetooth® radio transmission, stepless temperature selection via two buttons, two fixed value buttons and an LCD display, magnetic wall bracket and batteries (included in delivery).

IP 20. Dimensions (H × B × T): 5.8 × 12.5 × 1.9 cm

FXS 3 (C): Part no. 3200-34027



FXE 3 (C) remote control adapter (optional)

Bluetooth® remote control adapter for integration into the instantaneous water heater to connect the water heater to a smartphone / tablet or the FX3 remote control. This adapter is required if the appliances are not yet equipped with an FX3 remote control.

FXE 3 (C): Part no. 3200-34026



Apple



Android